

GEOGRAPHY FORM I, END OF TERM 2 -2021. TIME 1HR 45 MINUTES

Answer all the questions in the spaces provided

NAME..... CLASSADM.....

1. a) Name two branches of Geography. (2mks)

b) What is the relationship between Geography and Mathematics? (2mks)

2. The diagram below represents the internal structure of the earth. Use it to answer question a)

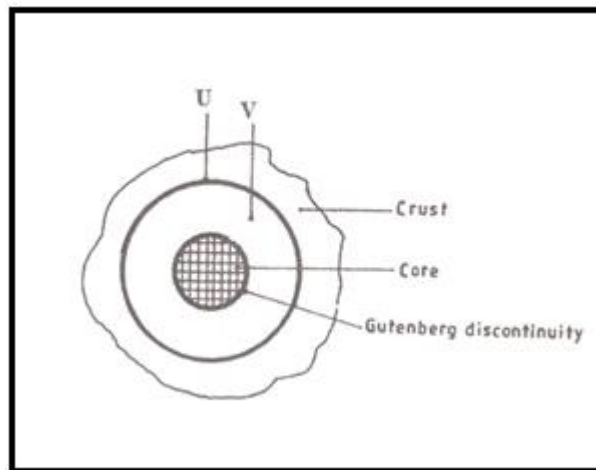

a) Name the parts marked U and V. (2mks)

b) Describe the composition of the
i) Crust. (4mks)

ii) Core.

(4mks)

3. a) i) Describe the solar system.

(2mks)

ii) The local time at manual 60°W is 11.30am. What is the time in Nairobi 37°E . (3mks)

b) Give five proofs that the earth is spherical. (5mks)

c) State two effects of the rotation of the earth. (2mks)

4. a) i) Define the term weather. (2mks)

ii) Explain how the following factors influence weather (4mks)

- Cloud cover.

- Local winds. (4mks)

The diagram below represents a weather measuring instrument. Use it to answer question (b)

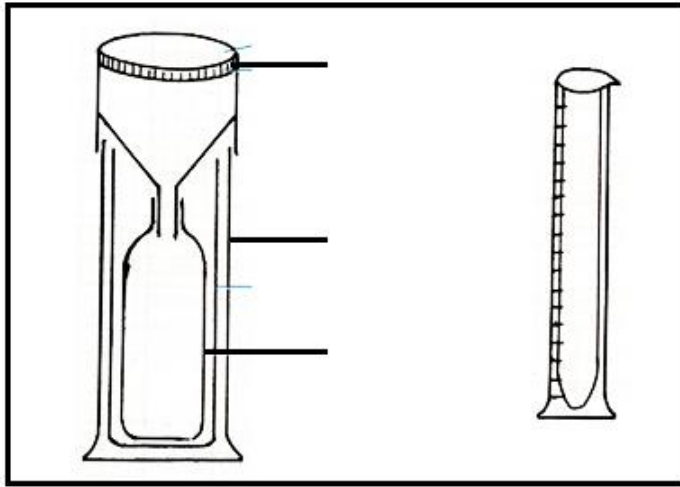

b) Which element of weather is measured using the instrument shown above? (1mk)

ii) Describe how the instrument is used. (3mks)

c) The table below shows the temperature and rainfall readings for station T in one week. Use it to answer question (c)

Day	Mon	Tue	Wed	Thu	Fri	Sat	Sun
Temperature °C	23	23	24	21	25	25	23
Rainfall in mm	50	49	49	45	60	60	49

c) i) Calculate:

The range of temperature for the week. (1mk)

The mean weekly rainfall. (2mks)

ii) State four benefits of weather forecasting. (4mks)

d) Give four characteristics of the stratosphere. (4mks)

5. Suppose your class carried out a field study on weather around your school environment;

i) Give four methods the class used to collect data in the field. (4mks)

ii) State three advantages of studying weather through fieldwork. (3mks)

iii) State three problems likely to be encountered during fieldwork. (3mks)

6. a) Give three types of maps. (3mks)

b) State any two uses of maps. (2mks)

c) i) Name two types of scales. (2mks)

ii) Give the uses of scales in a map. (2mks)