

FORM 2 TERM 3 2020

CHEMISTRY

1(a). The table below shows some properties of chlorine, bromine and iodine .

element	formula	Colour and state room temperature	Solubility in water
Chlorine	Cl ₂	(i)	Soluble
Bromine	Br ₂	Brown liquid	(ii)
iodine	I ₂	(iii)	Slightly soluble

Complete the table by giving the missing information in (i), (ii) and (iii) above. (3mks)

(b). Chlorine gas is prepared by reacting concentrated hydrochloric acid with either Manganese (IV) oxide or Potassium permanganate.

(i). Write the equation for the reaction between concentrated hydrochloric acid and Manganese (IV) oxide. (1mk)

(ii). What is the role of manganese (iv) oxide in this reaction? (1mk)

(iii). When potassium permanganate is used instead of manganese (iv) oxide, heating is not required. Explain. (1mk)

(iv). Give two advantages of using potassium permanganate over manganese (IV) oxide. (2mks)

(v). Iron metal reacts with chlorine to form substance E. identify substance E. (1mk)

(vi). Write a chemical equation to represent the reaction in (V) above .(1mk)

(c). The set up below was used to collect gas F produced between water and calcium

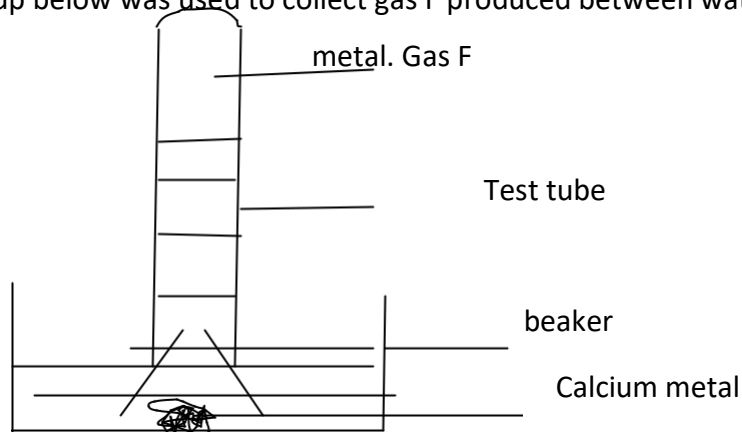

(i). Name gas F. (1mk)

(ii). Write an equation for the production of gas F. (1mk).

(iii). At the end of the experiment, the solution in the beaker was found to be a weak base. Explain why the solution was a weak base. (2mks)

(iv). Give one laboratory use of the solution formed in the beaker. (1mk)

2(a). The set up below was used to investigate the reaction of sodium metal with chlorine gas. Study it and answer the questions that follow.

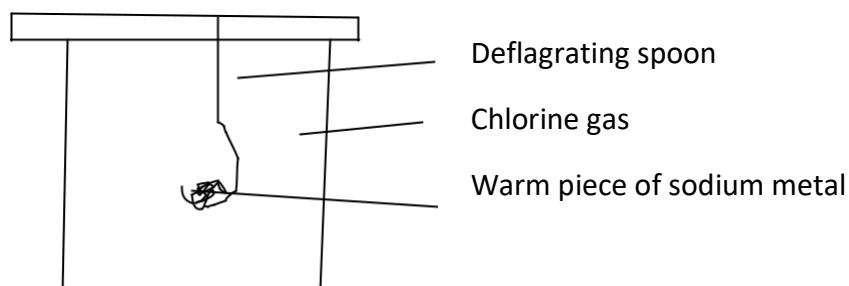

(i). State two observations that would be made in the gas jar. (2mks)

Compiled and supplied online by Schools Net Kenya | P.O. Box 85726 – 00200, Nairobi |
Mob. 0711 8822 27 | Email: infosnkenya@gmail.com | Order answers online at www.schoolsnetkenya.com

(ii). Write an equation for the reaction that occurred. (1mk)

(iii). Name one use of the product formed. (1mk)

(b). In an experiment, dry hydrogen gas was passed over heated lead (II) oxide as shown

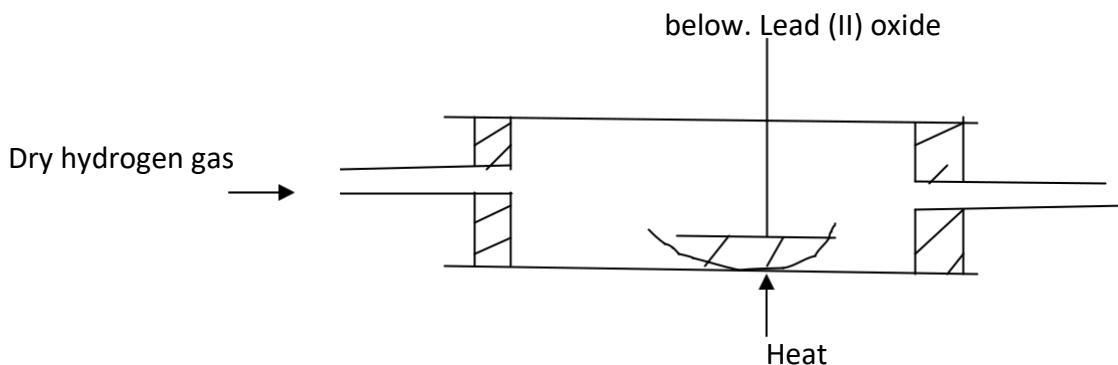

(i). State the two observations made in the combustion tube after the experiment. (2mks)

(ii). Write a chemical equation for the reaction that occurred in the combustion tube. (1mk)

(iii). What property of hydrogen gas is shown by the reaction in b (ii) above? (1mk)

3. In an experiment, a test tube of chlorine gas was inverted in water as shown in the diagram. It was then left to stand in sunlight for one day.

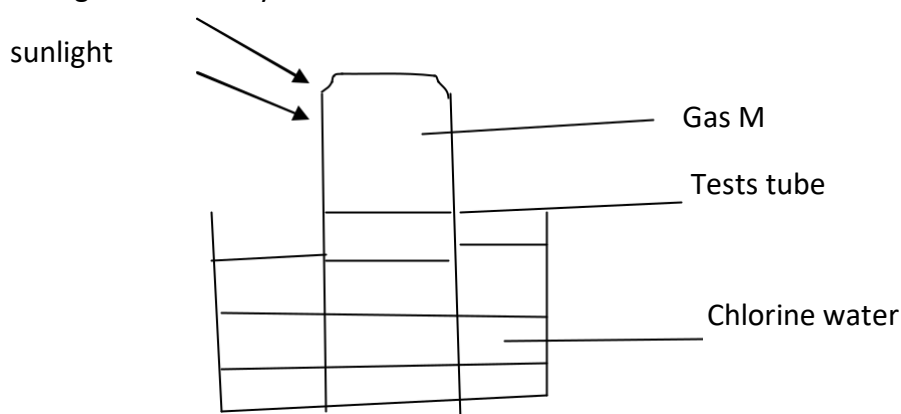

After one day, a gas M was found to have collected in the test tube as shown above.

(i). identify gas M. (1mk)

(ii). Suggest whether the PH of the solution the beaker would increase or decrease after one day. Give an explanation. (2mks)

(iii). The colour of chlorine water was observed to have changed from pale yellow to colourless after one day. Explain. (2mks)

(iv) Write an equation to support your answer in 3(iii) above. (1mk)

(v). State and explain the observation made when a moist blue litmus paper was placed at the mouth of the test tube containing chlorine gas. (3mks)

(vi). Write an equation to show how the process in 3(v) above occurs. (1mk)

(vii). Give two uses of chlorine gas. (2mks)

4(a). The chart below is an outline of part of the periodic table.

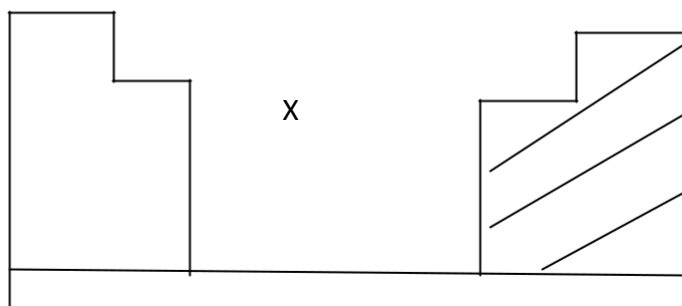

(i). With the help of vertical and horizontal lines, indicate the direction of increasing non-metallic nature of the elements. (2mks)

(ii). Which type of elements are represented :

By X ? (1mk)

In the shaded area? (1mk)

(b)(i). Element A is in the same group of the periodic table as chlorine. Write the formula of the compound formed when A reacts with magnesium. (1mk)

Compiled and supplied online by Schools Net Kenya | P.O. Box 85726 – 00200, Nairobi |
Mob. 0711 8822 27 | Email: infosnkenya@gmail.com | Order answers online at www.schoolsnetkenya.com

(ii). Soot is one of the environmental pollutants.

I.Explain the term pollutant.

(1mk)

II.State how soot is formed from hydrocarbons.

(1mk)

(iii). What role do the following play in the commercial preparation of oxygen gas?

I. Concentrated sodium hydroxide.

(1mk)

II. Concentrated Sulphuric (VI) acid.

(1mk)

(b). Study the diagram below and answer the questions that follow.

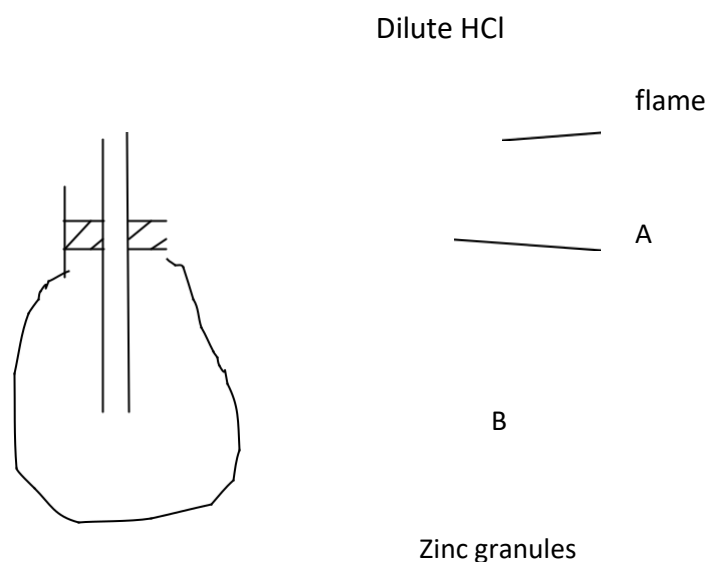

(i).Write a chemical equation for the reaction that occurred at points:

I. A

(1mk)

II. B

(1mk)

(ii). A student set up the experiment bellow to collect gas K. the glass wool was heated before heating the magnesium coil.

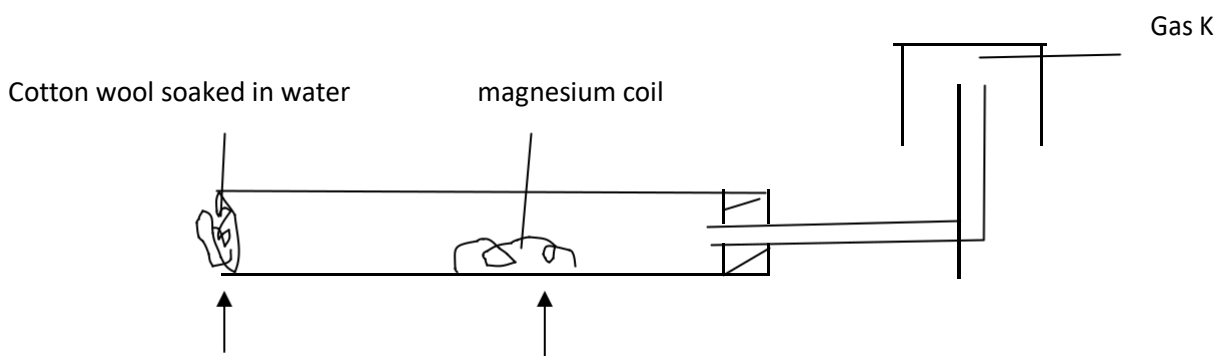

heat

heat

(a). Explain why it was necessary to heat the moist cotton wool before heating the magnesium. (2mks)

(b). Identify gas K. (1mk)

(c). what property of gas K makes it possible to be collected by the method shown? (1mk)

(d). Write a chemical equation for the reaction that produced gas K. (1mk)

(e). The diagram represents two methods of gas collection in the laboratory.

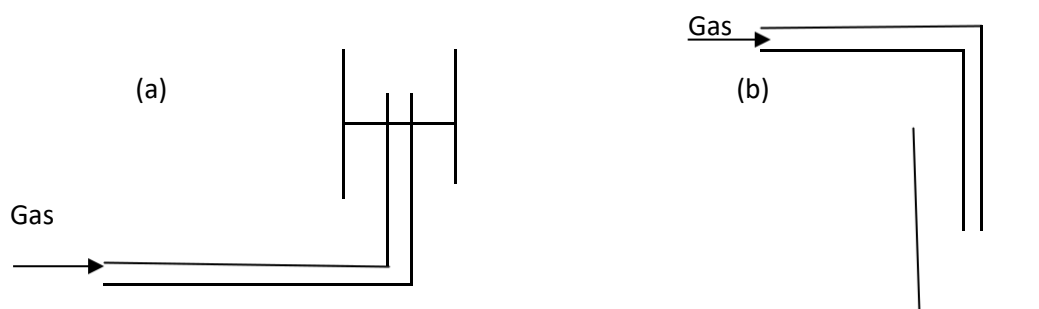

(i). Name the methods of gas collection above. (2mks)

(ii). Which method is suitable for collecting dry carbon (IV) oxide gas? Give a reason . (2mks)

5. The curves bellow represent the variation of temperature with time when pure and impure samples of a solid were heated separately.

A

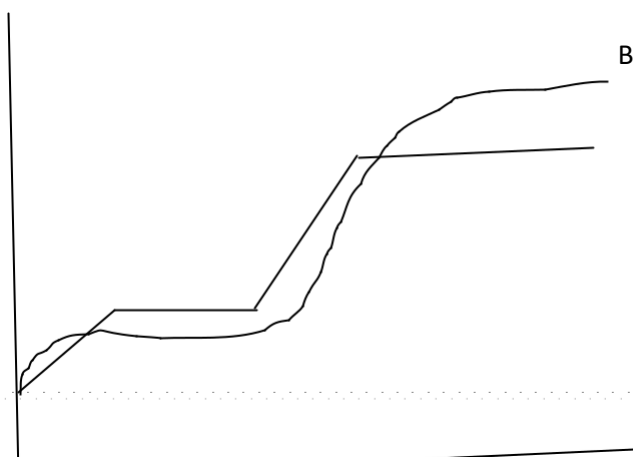

Temperature

Compiled and supplied online by Schools Net Kenya | P.O. Box 85726 – 00200, Nairobi |
Mob. 0711 8822 27 | Email: infosnkenya@gmail.com | Order answers online at www.schoolsnetkenya.com

(a). Which curve represents the variation in temperature for pure solid? Explain. (2mks)

(b) State the effect of an impurity on the melting and boiling points of a pure substance. (2mks)

(c). Name two gases used with oxygen in welding. (2mks)

6. The set up below was used to study some properties of air.

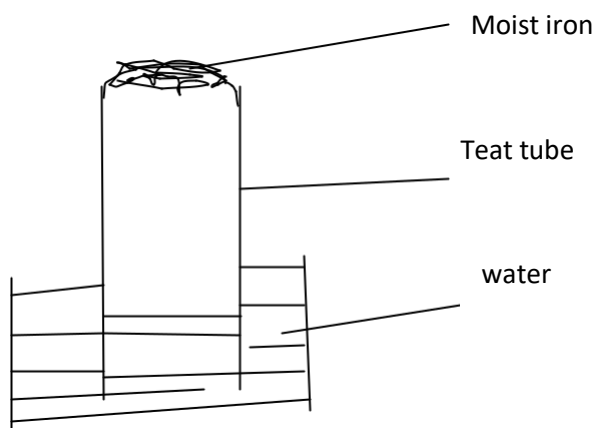

.Draw another diagram to show the level of water in the test tube after 24 hours. Explain the observations. (3mks)

(ii). State and explain one observation made on the moist iron after 24 hours. (2mks)

(iii). State one disadvantage of rusting. (1mk)

(iv). Fractional distillation of liquid air is usually used to separate various gaseous mixtures in air. Explain how nitrogen is obtained. (1mk)

(v). The PH of a soil sample in a given area was found to be 5.5. an Agricultural officer the addition of lime (calcium oxide). State the function of lime in the soil. (1mk)

Compiled and supplied online by Schools Net Kenya | P.O. Box 85726 – 00200, Nairobi |
Mob. 0711 8822 27 | Email: infosnkenya@gmail.com | Order answers online at www.schoolsnetkenya.com