

# FORM FOUR CLUSTER KCSE MODEL2

## PHYSICS PAPER 2 QUESTIONS

### SECTION A (25 Marks)

1. The figure 1 shows the face of a wall clock as seen on the plane mirror.

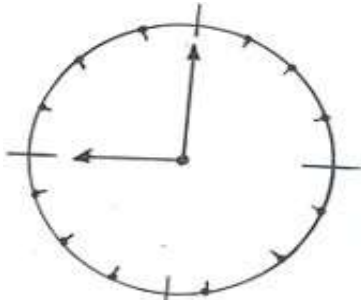

Fig 1

What is the correct time as seen on the clock itself?

.....

.....

2. **Figure 2** represents an object **O** and the image **I** formed by a concave mirror.

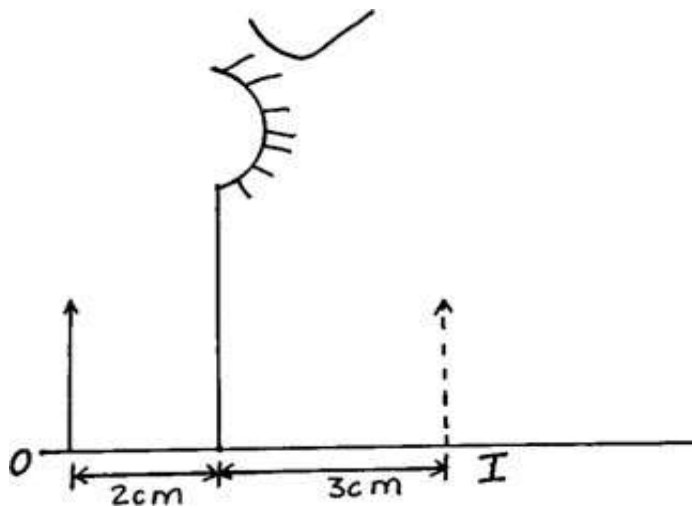

By suitable rays, determine the focal length of the mirror.

.....

.....

.....

3. The figure shows ultraviolet light striking a clean zinc plate on a positively charged leaf electroscope.

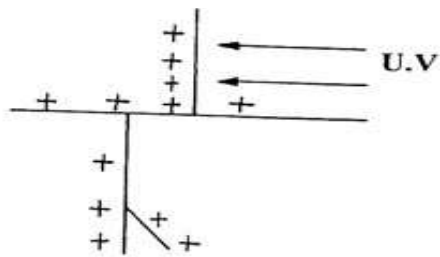

**Fig.3**

Explain the following observations.

i) The leaf does not fall.

.....  
 .....  
 .....

ii) When the same experiment is carried with a negatively charged electroscope, the leaf falls.

.....  
 .....

4. In an x-ray tube it is observed that the intensity of x-rays produced increased when the potential difference in the filament is increased. Explain this observation.

.....  
 .....  
 .....

5. The figure below shows two ways of connecting a cell to two resistors in a circuit. The ammeter readings are shown. Calculate the internal resistance of the cell.

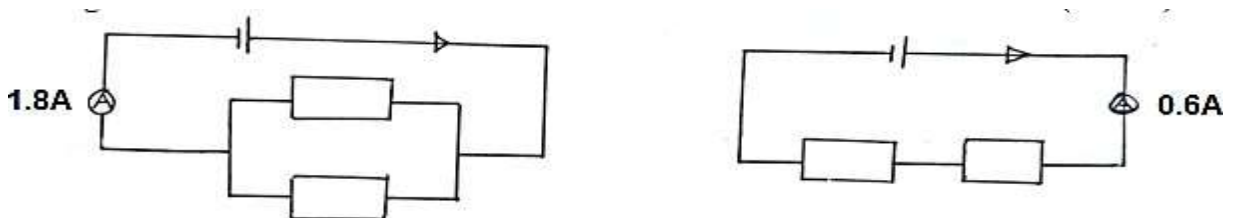

6. State what is meant by the term threshold frequency as used in photo-electricity?

.....  
 .....

7. The figure below shows region of electromagnetic spectrum.

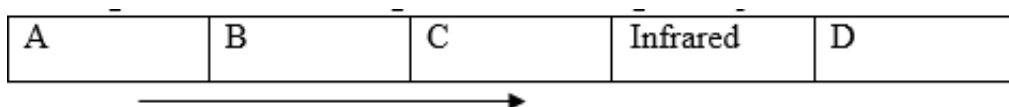

Increasing wavelength

Name the region that represents:

i) A.....

ii) C.....

8. Determine the speed of light in water given that the speed of light in air is  $3.0 \times 10^8 \text{ms}^{-1}$  and the refractive index of water is 1.33.

.....  
.....  
.....  
.....

9. A student holds a book at arms length to read. Name the effect of her vision and the lens he should use to correct the defect.

.....  
.....

10. Explain how polarization is reduced in leclanchi cell.

.....  
.....  
.....

11. The following reaction is part of a radioactiveseries

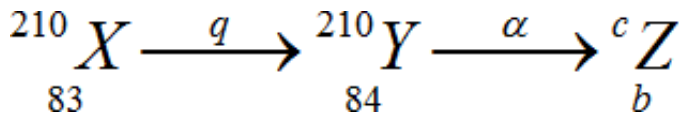

Identify the radiation q and determine the value of b.

q.....

b.....

12. The wave shown in the diagram below has a velocity of 200m/s.

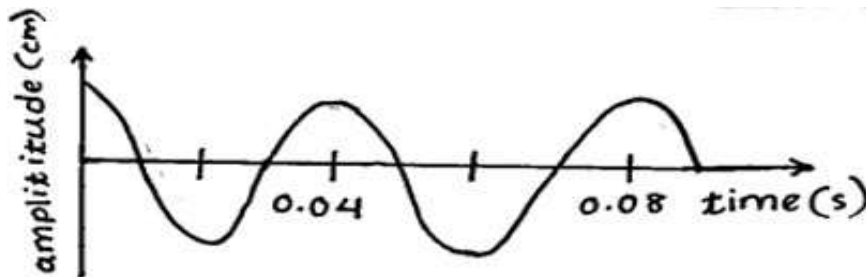

Determine the wavelength of the wave.

.....  
.....  
.....

13. Two men are selling trees at points A and B separated by a valley. Neither man can see the other. When they hear the sound from the axes, each of them thinks there are two other men across the valley. Explain their observation.

.....  
.....

.....  
.....

**SECTION B (55 Marks)**

14. a) The SI unit of capacitance is the Farad. Define the Farad.

.....  
.....  
.....

b) The figure below shows two aluminium plates X and Y of equal dimensions 30cm x 30cm fixed on wooden support and fairly close to each other but separated by a distance d.

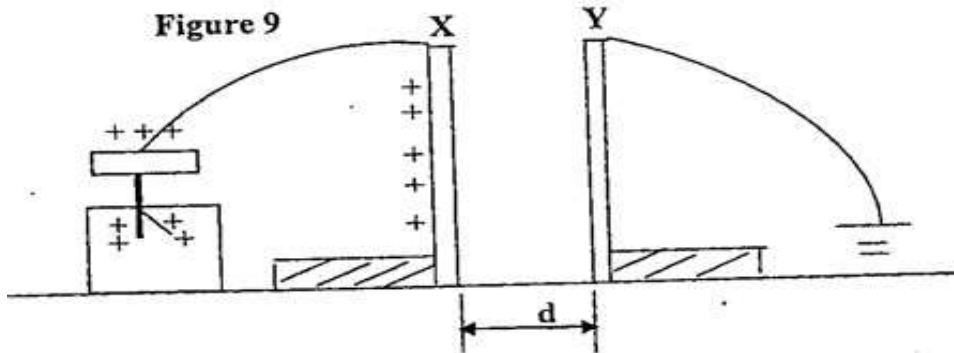

Plate X is charged to a high voltage and then connected to uncharged gold leaf electroscope. The area of overlap is maintained but the distance of separation d, is varied by moving plate Y. i) What happens to the divergence of the electroscope when plate Y is moved closer to plate X? Give a reason for your answer.

.....  
.....

ii) What happens to the leaf divergence when plate Y is moved away from plate X while area of overlap is maintained?

.....  
.....

iii) What effect does the movement of plate (Y) above have on the capacitance?

.....  
.....  
.....

iv) The area of overlap is decreased by moving plate Y parallel to plate X but keeping the distance of separation constant. What happens to the leaf divergence?

.....  
.....

v) The area of overlap and the distance of separation are kept constant; but an insulator introduced between the plates, what happens to the divergence of the leaf?

.....

.....  
.....

c)

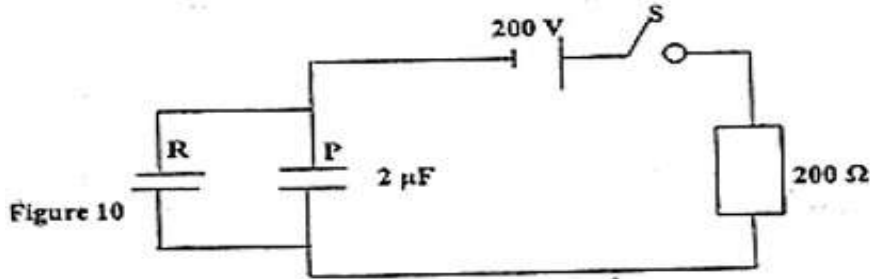

Figure 10  
A  $2\mu\text{F}$  capacitor P is charged to a potential of 200V, then the supply is disconnected as shown in figure 10 above. The charged capacitor is then connected to another uncharged capacitor (R). The p.d across the parallel arrangement is 80V. Calculate:  
i) The capacitance of the second capacitor.

.....  
.....  
.....

ii) The final charge on each capacitor.

.....  
.....  
.....

iii) What is the initial energy stored by capacitor P?

.....  
.....  
.....

15. a) Define the following terms:

i) doping

.....  
.....

ii) diode

.....  
.....

b) With the aid of a circuit diagram, differentiate between forward biased and reverse diode.

.....  
.....  
.....

c) The figure below shows an incomplete circuit for full wave rectification:-

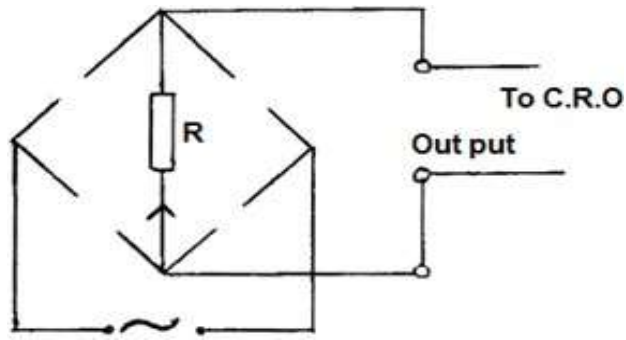

i) Complete the diagram to show how the diodes should be arranged for the current to flow through R in the direction shown.

ii) Sketch the output voltage as observed in the C.R.O.

.....  
 .....  
 .....

16. a) i) What causes electrical resistance in a conductor.

.....  
 .....

ii) Three resistors of resistance  $2.0\Omega$ ,  $4.0\Omega$  and  $6.0\Omega$  are connected together in a circuit. Draw a circuit diagram to show the arrangement of the resistor which gives effective resistance of  $3.0\Omega$

.....  
 .....  
 .....

b) i) Define the term e.m.f. (1mark)

.....

c) The graph below shows the voltage current relationship for a certain battery.

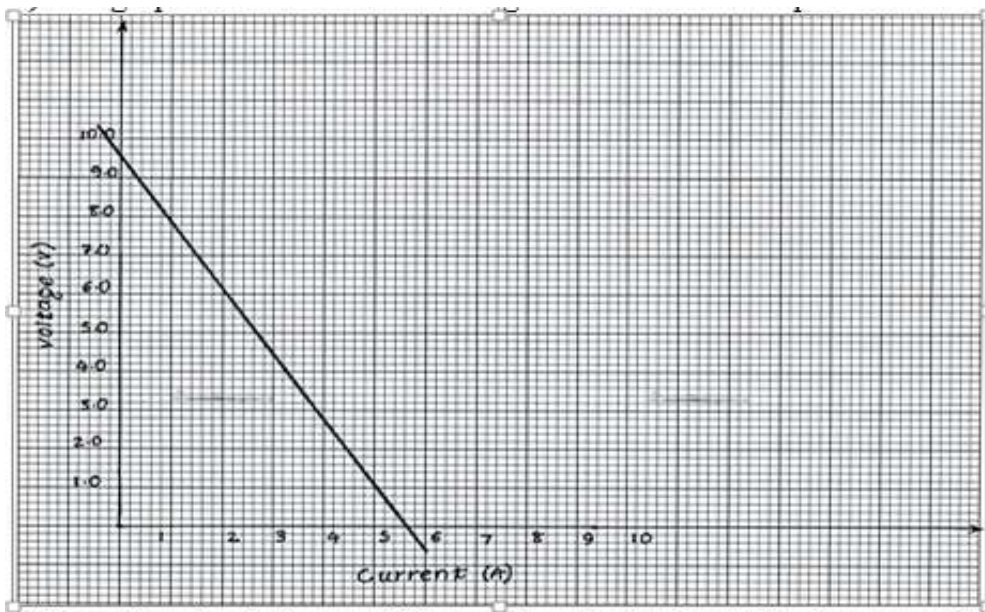

- i) Draw the circuit that could be used to obtain the results shown on the graph.  
 ii) From the graph determine the e.m.f of the battery.

.....  
 .....  
 .....

- iii) From the graph, determine the internal resistance of the battery.

.....  
 .....  
 .....

17. a) The diagram below shows a cathode ray tube of a cathode ray oscilloscope (CRO)

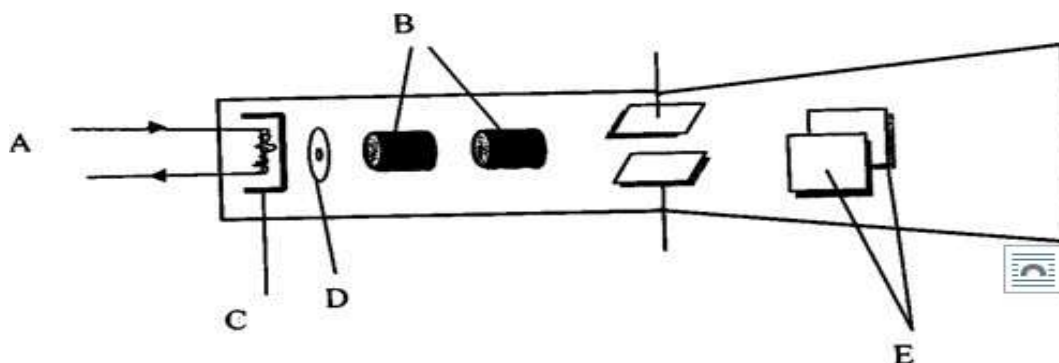

- i) Name the parts labeled B and E.

.....  
 .....

ii) What property does the part labeled C have for its efficient functioning.

.....  
.....

iii) Explain how electron are produced in the tube.

.....  
.....  
.....

iv) Explain the purpose of part labeled D and how it works.

.....  
.....

v) Why is it necessary to earth the screen?

.....  
.....

vi) It is possible for X-rays to be produced in this tube. Explain

.....  
.....

The figure below shows a CRO ac display.

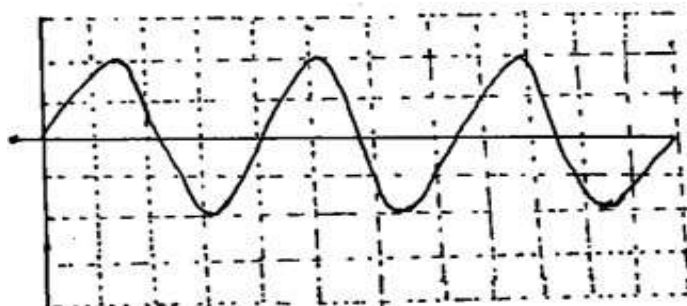

Given that the time base control is 50ms/div and the Y-gain is at 200V/div, determine:

i. The frequency of the ac. Signal.

.....  
.....  
.....

ii. The peak voltage of the input signal.

.....  
.....  
.....

18. a) i) State Lenz's law of electromagnetic induction.

.....  
.....  
.....

ii) Give two structural features in transformer design which help in achieving high efficiency.



.....  
.....  
.....  
.....

b) What is the advantage in each case of transmitting power at:-

i) Very high voltages?

.....  
.....

ii) Alternating voltage?

.....  
.....

c) A large sub – station transformer is used to step down from 11000V to 450V. Determine the ratio of the turns in the primary to secondary coils.

.....  
.....  
.....

d) A household uses 1500W television for 6 hours and three 100W bulbs for an average of 8 hours daily (assume that a month has 30 days).

Calculate

i) The number of kWh per month.

.....  
.....  
.....  
.....

ii) The monthly bill if electricity is charged as follows; ksh 6 per kWh, fuel consumption at 335 cents per kWh and forex adjustment at 76 cents per kWh.

.....  
.....  
.....