

FORM FOUR CLUSTER KCSE MODEL 2

AGRICULTURE PAPER 2 QUESTIONS

SECTION A (30 Marks)

1. Name the pig breed which is black with a white belt the enlives the shoulders, including the front legs and has dropping ears over the face. (½ mark)

.....
.....
.....

2. Define the following terms as used in livestock nutrition.

a) Digestibility. (1mark)

.....
.....

b) Ration (1mark)

.....
.....

3. Name two animal drawn implements. (1mark)

.....
.....

4. List four features of a good grain store. (2marks)

.....
.....
.....
.....

5. State the function for each of the following parts in the chicken digestive system. (1 ½ mks)

i. Crop

.....
.....

ii. Proventriculus

.....
.....

iii. Gizzard

.....
.....

6. State three breeding practices carried out on farm animals to ensure successful breeding. (1 ½ mks)

.....
.....
.....

7. Outline any four pre-disposing factors of scours. (2marks)

.....
.....
.....
.....

8. Give a reason for clipping needle –teeth in piglets. (1mark)

.....
.....

9. State four factors to consider when siting farm structures. (2marks)

.....
.....
.....
.....

10. Name the most appropriate tool for each of the following operations.

a) Removing metal chipping in files. (½ marks)

.....

b) Cutting wood along the grains. (½ marks)

.....

c) Cutting identification mark on ears of an animal. (½ mark)

.....

11. . Give four advantages of tractor hire services. (2marks)

.....
.....
.....
.....

12. Give four factors influencing milk let down in dairy cattle production. (2marks)

.....
.....
.....
.....

13. List any four materials collected by bees. (2marks)

.....
.....
.....
.....

14. State three reasons for out breeding. (1 ½ marks)

.....
.....
.....

15. Name four viral diseases in livestock. (2marks)

.....
.....
.....
.....

16. State one function of each of the following parts of a male’s reproductive system.

a) Testis (½ mark)

.....
b) Sperm duct (½ mark)

.....
c) Penis (½ mark)

.....
17. State four advantages of natural feeding in calf rearing.

.....
.....
.....

18. Outline four heat signs in rabbits. (2marks)

.....
.....
.....

SECTION B (20 Marks)

19. . The diagram below shows a livestock parasite.

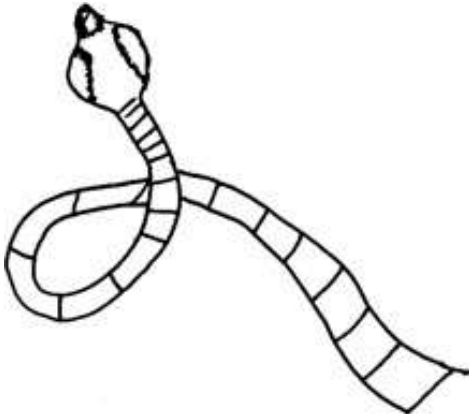

a) Identify the parasite. (1mark)

.....

b) Name two species of livestock the parasite infests. (2marks)

.....
.....

c) Give two forms in which the parasite is found in livestock. (2marks)

.....
.....

20. . Below is a diagram illustrating a bee hive? Study it and answer the questions that follow.

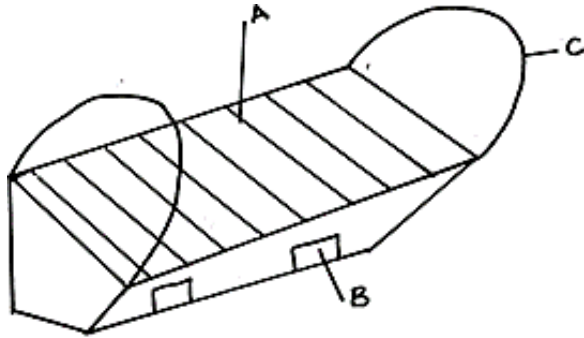

a) Identify the type of bee hive illustrated above. (1mark)

.....

b) Name the parts labelled A and B.

A..... (1mark)

B..... (1mark)

c) State two advantages of the above hive compared to other hives. (2marks)

.....

SECTION C (40 Marks)

21. Study the diagram below showing digestive system of a non – ruminant (rabbit). Use it to answer the questions that follow.

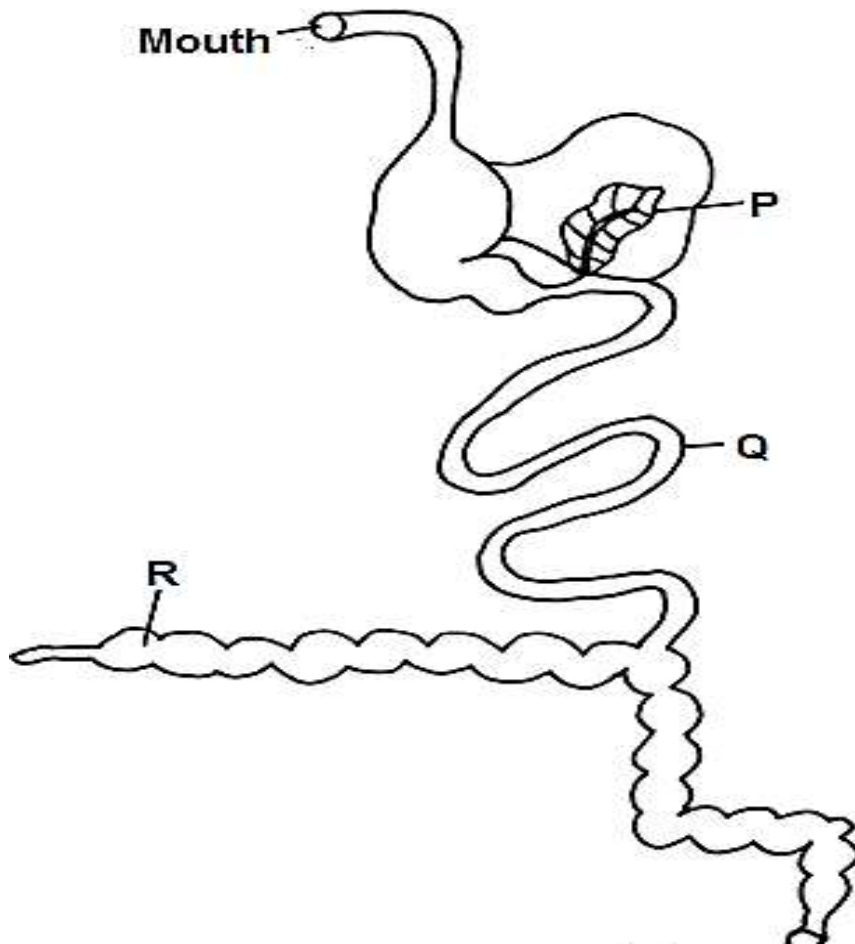

a) Name the part labelled P and Q

. P.....(½ mk)

Q..... (1mk)

b) State the function of the part labelled R. (1mark)

.....

c) State three ways in which digestion in rabbits differ from that of cattle. (3marks)

.....

.....

.....

22. . The diagrams M, N, P and Q represent some farm tools.

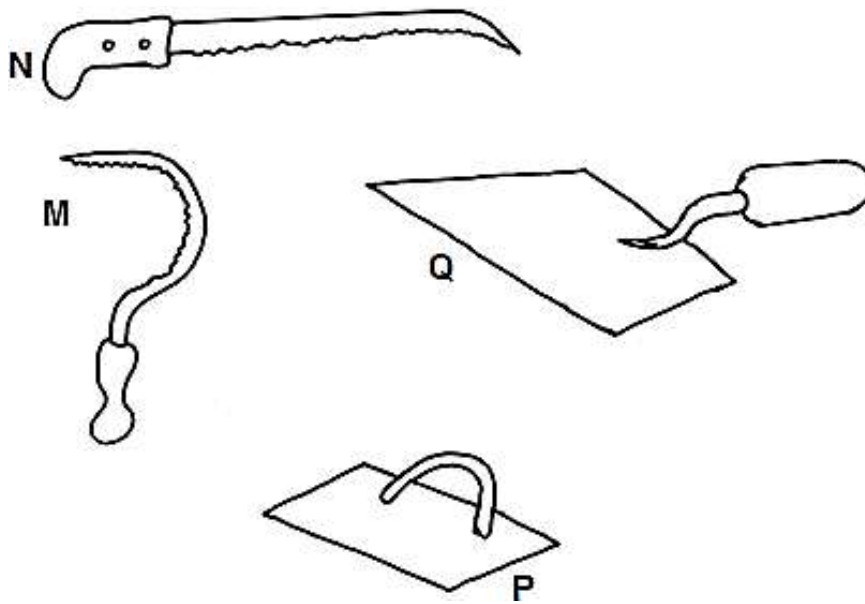

i) Identify tools. (2marks)

- M.....
 N.....
 P.....
 Q.....

ii) Give the use of each of the tools named above.

- M..... (½ mark)
 N..... (½ mark)
 P..... (½ mark)
 Q..... (½ mark)

iii) State two maintenance practices that should be carried out on tool M. (1mark)

.....

23. Describe artificial brooding of layer chicks. (20marks)

24. a) Describe the structural requirement to be considered when constructing a calf pen. (10marks)

b) Describe mastitis disease in dairy cattle under the following sub-headings

i) Two causal organisms. (2marks)

ii) Pre-disposing factors. (8marks)

25. . a) Outline the factors that influence the choice of building materials. (5marks)

b) Compare the use of animal drawn implement to tractor drawn implement in the farm. (10marks)

.....

.....

.....
.....
.....
.....
.....
.....
.....