

## FORM FOUR CLUSTER KCSE MODEL12

### CHEMISTRY PAPER 2 QUESTIONS

1.

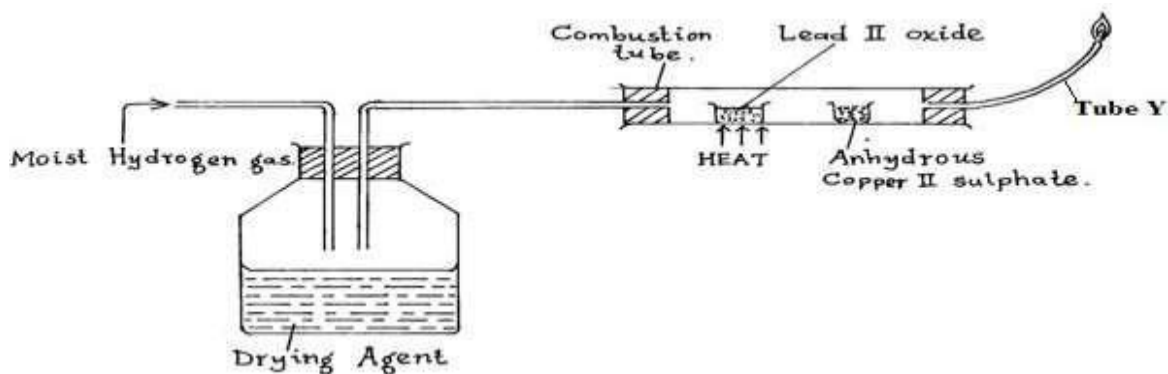

The set-up above was used to investigate some properties of hydrogen gas. Study it and answer the questions that follow;

a) Identify one mistake in the set -up and state how it can be corrected. (1mark)

.....

b) Name a suitable liquid that can serve as a drying agent in the set up. (1mark)

.....  
.....

c) State the observations you would expect to make in the combustion tube as the experiment progresses. (1mark) .....

.....

d) Name and explain the:

(i) Oxidizing agent. (1mark)

.....  
.....

ii) Reducing agent. (1mark)

.....  
.....

e) Write an equation for the reaction that occurs at the tip of the tube Y. (1mark)

.....  
.....

f) Why is it necessary to burn the gas escaping at the tip of tube Y. (1mark)

.....  
.....

g) Why is it necessary to clamp a combustion tube in a slanting position? (1mark)

.....  
.....

h) Why should the supply of hydrogen gas continue until the apparatus are cool? (1mark)

.....

.....

i) Explain what would happen if lead II oxide were replaced with calcium oxide. (1mark)

.....  
.....

2. i) In an experiment, a piece of magnesium ribbon was cleaned using a sand paper. 3.6g of the clean magnesium ribbon was ignited over a Bunsen burner flame and lowered into jar of oxygen where it burned completely into a white ash. On cooling the ash weighed 6g.

a) Why was it necessary to clean the ribbon? (1mark)

.....  
.....

b) Explain the increase in mass. (1mark)

.....  
.....

c) Write an equation for the reaction between magnesium and oxygen. (1mark)

.....  
.....

d) The ash was shaken with distilled water and filtered. Explain the expected observation if pieces of blue and red litmus papers are placed in the filtrate. (2marks)

.....  
.....  
.....

e) Calculate the volume of oxygen consumed during the reaction (O= 16, Mg =24, Molar volume of a gas at room temperature is 24,000cm<sup>3</sup>) (2marks)

.....  
.....  
.....

f) If a piece of carbon is burnt completely in oxygen, the remaining ash weighs less than the original piece of carbon. Explain (2marks)

.....  
.....  
.....

ii) Metal S removes oxygen combined with P. Q reacts with an oxide of R but not with an oxide of P. P reacts with cold water but Q does not. a) Which is the most reactive metal ( 1/2 mark)

.....  
.....

b) Which is the least reactive metal ( 1/2 mark)

.....  
.....

c) Arrange the metals in order of reactivity starting with the most reactive. (1mark)

.....  
.....

3. The table below shows some properties of substances K and R (not their actual chemical symbols). Study it and answer the question that follow:

Element	Atomic number	M.Pt <sup>0</sup> C	B.Pt <sup>0</sup> C	Electrical conductivity
K	11	98	890	Good conductor
L	12	650	1110	Good conductor
M	13	660	2470	Good conductor
N	14	1410	2360	Poor conductor
O	15	44.2	280	Non- conductor
P	16	590	445	Non- conductor
		113		
Q	17	119	-35	Non- conductor
		-101		
R	18	-186	-186	Non- conductor

i) Explain in terms of structure and bonding why element N has very high melting point and boiling points. (2marks)

.....

ii) Which of the element K and M is likely to have higher electrical conductivity. Explain (2marks)

.....

iii) Why do elements O and P have two values of M.Pts? (1mark)

.....

iv) State one use of N based on electrical conductivity. (1mark)

.....

v) Explain in terms of structure and bonding why element K has a much lower M.Pt. than M. (2marks)

.....

vi) Two atoms of Q will spontaneously react to form a Q<sub>2</sub> molecule while two atoms of K will not react. Explain. (1mark)

.....

vii) Give an equation for the reaction between M and P. (1mark)

.....

viii) Draw a dot (•) and cross (x) diagram for the compound that is formed when N reacts with Q. (2marks)

.....

.....

4. Study the flow chart below and answer the questions that follow:

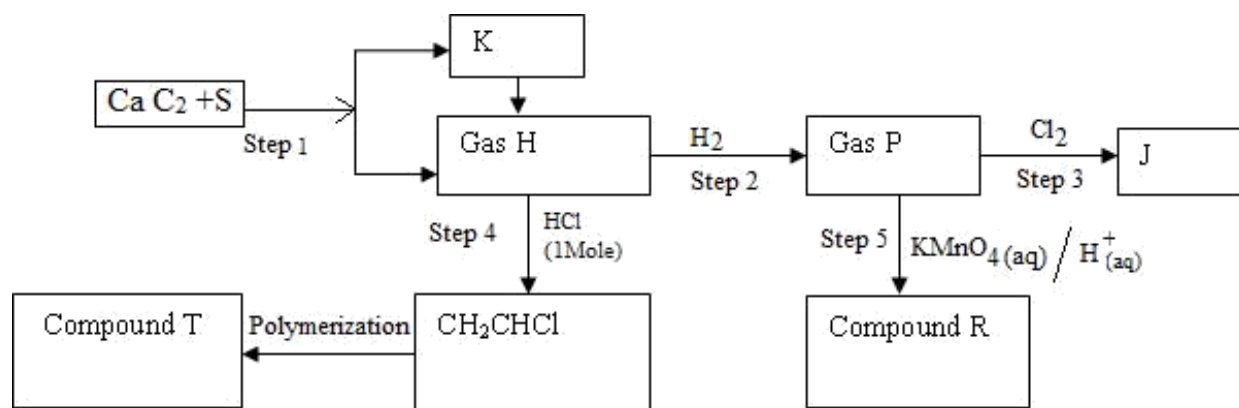

- i) Identify reagent S. (1mark)  
.....
- ii) Write the equation for the reaction taking place in step 1. (1mark)  
.....
- iii) Identify substance (K) .....  
.....
- iv) What names are given to processes below?  
 a) Process in step 2. (1mark) .....  
 b) Process in step 3. (1mark) .....  
 c) Process in step 4 (1mark) .....  
 d) Process in step 5 (1mark) .....  
 v) State the condition necessary for step 2. (1mark)  
 .....  
 vi) Draw and name the structural formula of substance T and R. (2marks)  
 Substance T .....  
 Substance R .....  
 .....  
 vii) Write equation for the reaction in step 3. (1mark)  
 .....  
 viii) State uses of product T. (1mark)  
 .....  
 ix) Draw structural formula of gas H. (1mark)  
 .....  
 .....

5. The diagram below shows the most important stages in the industrial manufacture of sulphuric acid. Study it and answer questions that follow.

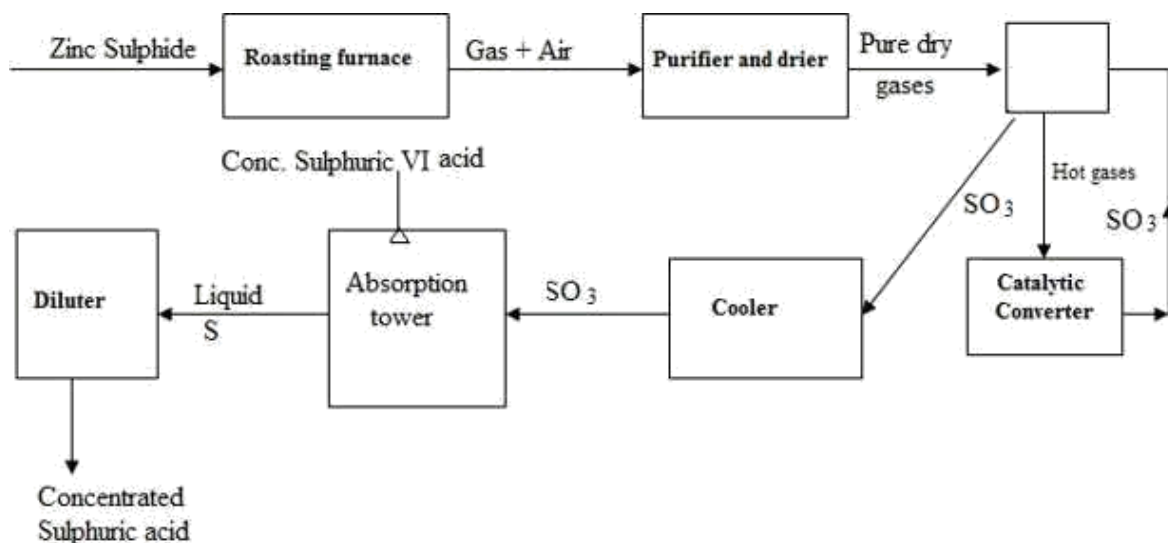

- i) Write an equation for the reaction that occurs in the roasting furnace. (1mark)
- ii) Why is it necessary that the gases be pure and dry (1mark)
- iii) What is the importance of passing the gases coming from the catalytic converter through heat exchanger. (1mark)
- iv) The reaction that take place in the catalytic chamber is as follows:

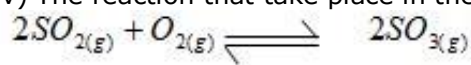

- a) Name the catalyst normally used. (1mark)
- b) Give two reasons why a pressure of 2 -3 atmospheres is used and not more. (1mark)
- c) A temperature of 400 -500C is maintained in the catalytic chamber. What would happen if the temperature fell below 400C. (1mark)
- v) Why is sulphur VI oxide not mixed directly with water? (1mark)
- vi) Give an equation for the reaction leading to the formation of liquid S. (1mark)
- vii) Name the main pollutant in the contact process. (1mark)
- viii) Name two methods by which pollution is controlled in the contact process. (1mark)

6. i) Draw a simple diagram to show how molten Lead bromide can be electrolyzed using graphite electrodes. (3marks)
- ii) Write half equations for the reaction at each electrode.

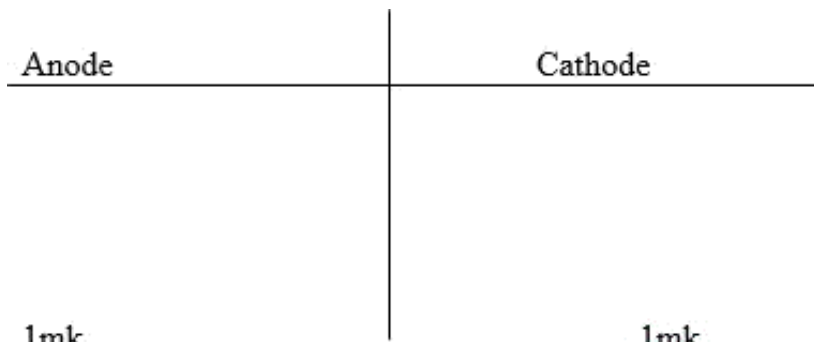

iii) State the observations made at each electrode. (2marks)

iv) Why are carbon (graphite) electrodes used? Explain. (2marks)

v) Why is the experiment done in a fume chamber? (1mark)

vi) Define the following terms:

a) Electrolysis (1mark) .....

b) Electrolyte (1mark) .....

7. Study the heating curves below and answer the questions that follow:

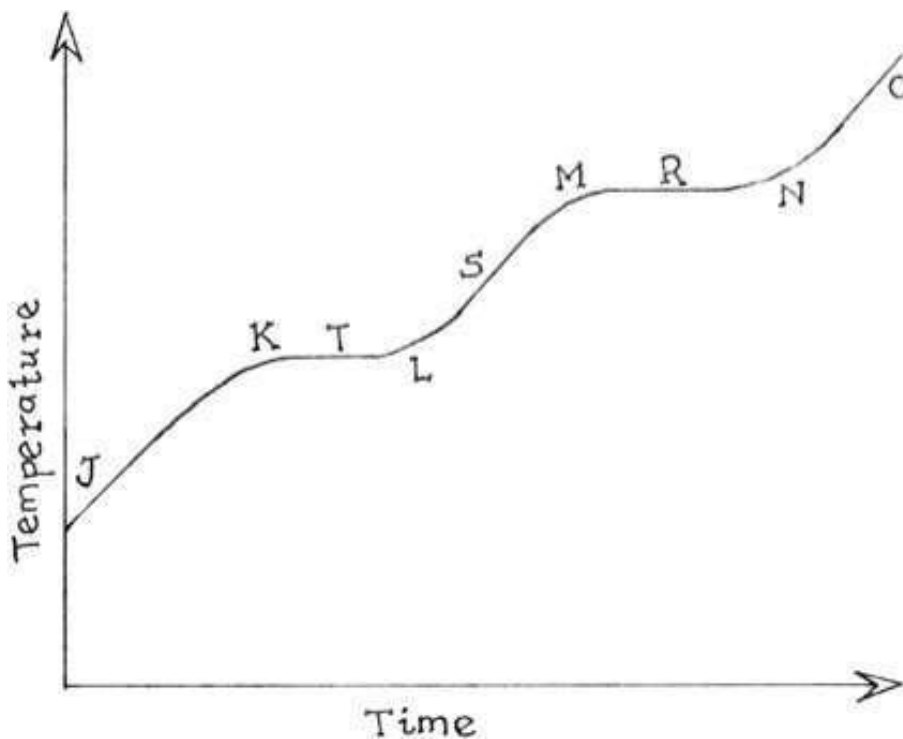

i) Which curve represents a pure sample? Explain. (2marks)

.....  
 .....

ii) What is the significant of points T and R.

Point T... (1mark)

Point R... (1mark)

iii) Explain using kinetic theory what is happening at points between K and L. (2marks)

.....  
.....

iv) Give the physical state of water at the following points:

T... (1mark)

S... (1mark)

v) Give the forces holding the water molecules together. (2marks)

.....  
.....

b) The diagram below shows inter conversions between the various states of matter. Study it and answer the questions that follow.

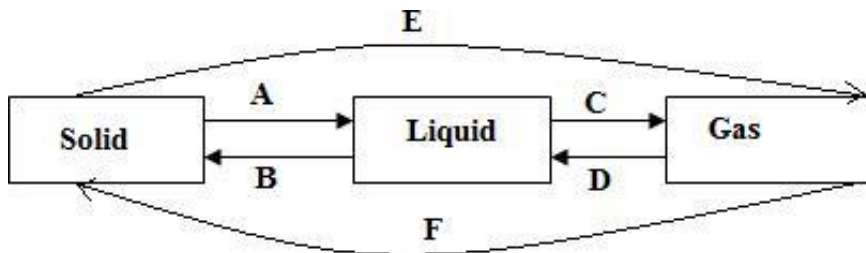

b) Name any two substances that can be recovered from a solid mixture using the processes labelled E and F. i)... ( ½ mark)

ii)... ( ½ mark)