

SUNSHINE SECONDARY SCHOOL MOCK 2015

PHYSICS PAPER 1

SECTION A (25 MARKS)

Attempt all the questions in the spaces provided.

1.State the name of the instrument used to take the following readings;

(i) 0.035m (1mk)

(ii) 0.00245m (1mk)

2. A vernier caliper which had an error of 0.02cm was used to measure the diameter of a spherical marble. If the actual diameter was 3.67cm, draw a vernier caliper scale showing its reading (2mks)

3. Fifty drops of oil have a volume of 1.0cm^3 . If a drop of oil forms an oil patch of diameter 20cm, determine the size of the oil molecule. (2mks)

4. (a) State Newton's third law of motion. (1mk)

(b) A man whose mass is 70kg stands on a weighing machine. When the lift ascends with an acceleration of 2.45m/s^2 , what is the reading on the scale. (2mks)

5. The figure below shows a sketch graph of velocity time graph for a body falling through a liquid. Explain the motion of the body between;

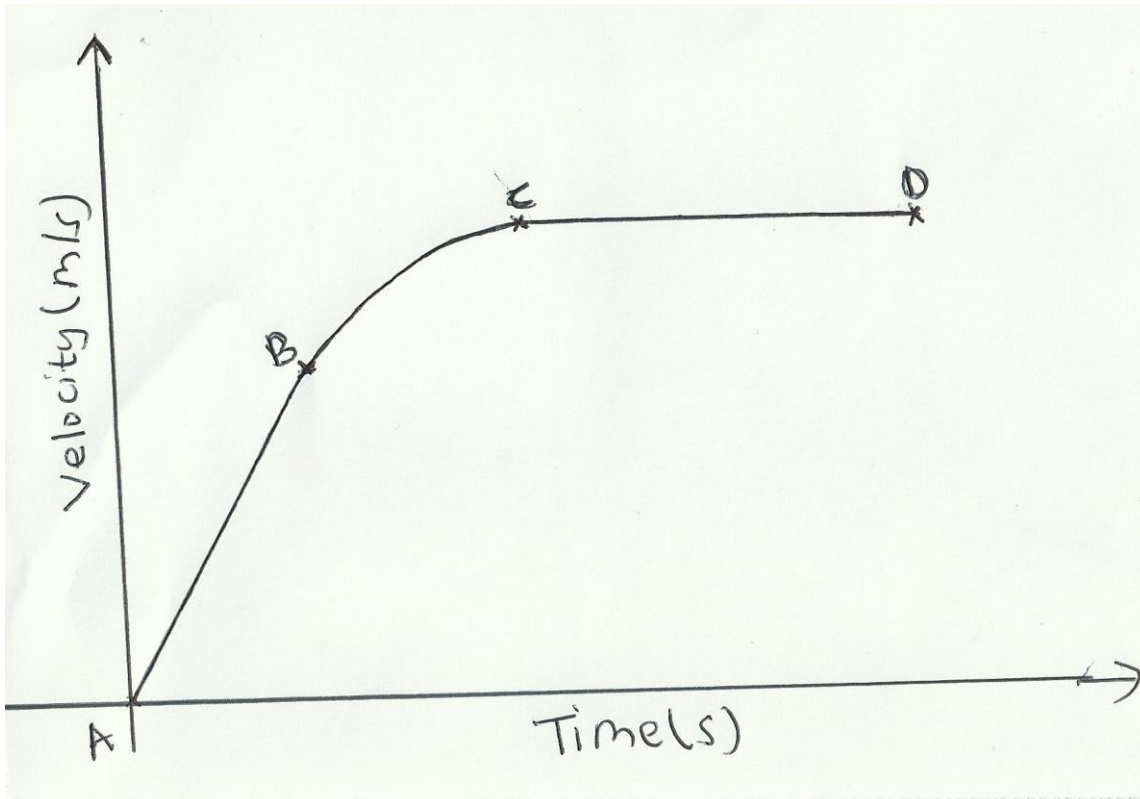

(a) A and B (1mk)

(b) B and C (1mk)

(c) C and D (1mk)

6. In a faulty mercury-in-glass thermometer was found that the mercury level stands at 3 cm mark in the tube at 0°C and 18 cm when in steam above boiling water at normal atmospheric pressure. Calculate the temperature when the mercury stands at 12 cm mark. (2mks)

7. A balloon filled with argon gas of volume 200 cm^3 at the earth's surface where the temperature is 20°C , and the pressure 760mm of mercury. If it is allowed to ascend to a height where the temperature is 0°C and the pressure 100mm of mercury, calculate the volume of the balloon. (2mks)

8.(a) The spiral springs shown in the figure below are identical. Each spring has a spring constant $K = 300\text{N/m}$. Each rod weighs 0.1N and each spring weighs 0.2N .

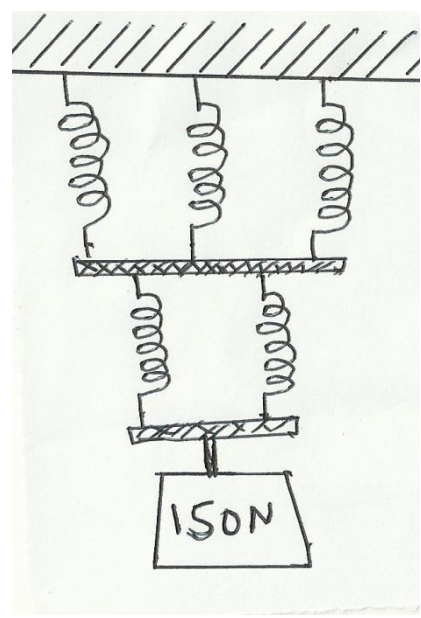

Determine the total extension caused by the 150N weight. (2mks)

(b) Apart from length of the spring and nature of material, state one other factor affecting the spring constant.(1mk)

9.State two conditions necessary for a body to be in equilibrium . (2mks)

10.(a) How does the position of the centre of gravity affect the stability of a body?(1mk)

(b)The figure below shows a uniform rod **AE** which is 40cm long. It has a mass of 2kg and pivoted at **D**. If 2N is acting at point **E**, and 30N force is passed through a frictionless pulley

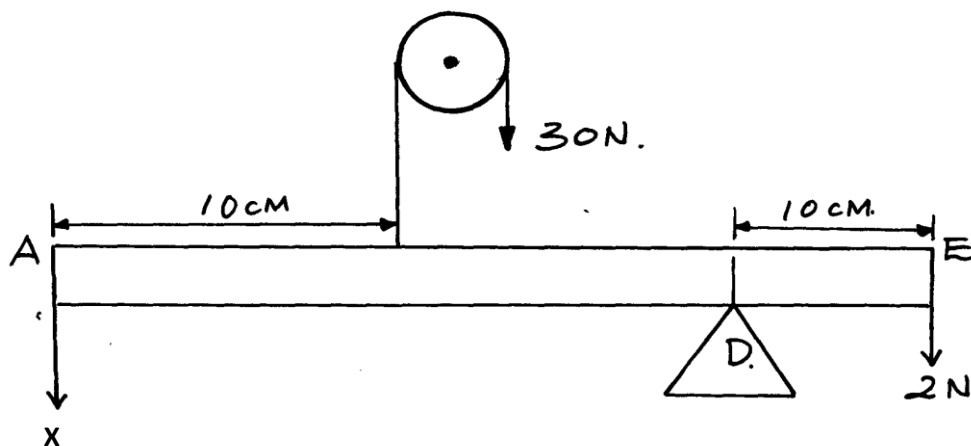

Find the force X acting at end A (3mks)

SECTION B (55 MARKS)

Attempt all the questions in this section.

11.(a) Sketch a block and tackle pulley system with three movable pulleys in the lower block and two fixed pulleys in the upper block. (2mks)

Find:

(b) (i) Velocity ratio (V.R.) (1mk)

(ii) An effort of 450 N is used to raise a load of 2700N. Determine:

- Mechanical advantage (M.A) (2mks)

- Efficiency of the pulley system. (2mks)

(iii) If all the wasted energy is used to raise the lower block and the frictional force between the pulleys and moving parts is 3.6N; determine the weight of the lower block. (2mks)

(c) If the load moved through a distance of 50cm, determine the useful work done by the effort. (3mks)

(d) James applied a force of 400N in pushing a stationary wall. If he took one hour to push the wall, calculate the power developed. (1mk)

12(a) The figure below shows dots which were made by a ticker timer-tape attached to a trolley. The trolley was moving in the direction shown.

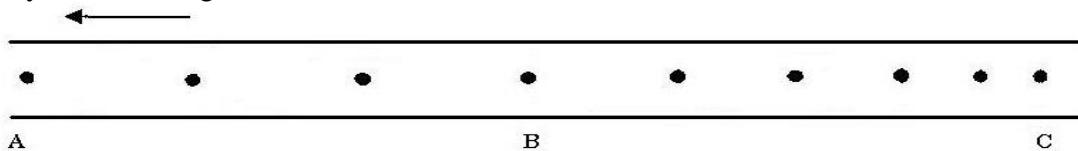

If the frequency used was 50 Hz, distance $AB = 12\text{cm}$ and $BC = 7.2\text{cm}$, determine

i) the velocities between AB and BC (2mks)

ii) the acceleration of the trolley. (2mks)

(b) An object is released to fall vertically from height of 100m. At the same time another object is projected vertically upward with velocity of 40m/s.

(i) Calculate the time taken before the objects meet (3mks)

(ii) At what height do the objects meet? (2mks)

(c) State two assumptions that were made when deriving the equation of continuity. (2mks)

13.(a) State Archimedes' principle

(1 mk)

(b) A block of length 50 cm, cross-sectional area of 5cm^2 and density 1.4 g/cm^3 is completely immersed in a liquid of density 1.08 g/cm^3 find

(i) The mass of the block

(2 mks)

(ii) The weight of the block in the liquid.

(2 mks)

(iii) The apparent loss in weight of the block if three quarter of it is immersed in the liquid.

(2 mks)

14.(a) Define specific latent heat of fusion

(1mk)

(b) You are provided with the following apparatus:

A filter funnel, a thermometer, a stop watch, ice at 0°C , an immersion heater rated P watts, a beaker, a stand, boss and clamp and a weighing machine.

Describe an experiment to determine the specific latent heat of fusion of ice. Clearly state the measurements to be made. (4mks)

(c) 200 g of ice at 0°C is added to 400g water in a well lagged calorimeter of mass 40g. The initial temperature of the water was 40°C . If the final temperature of the mixture is $X^{\circ}\text{C}$,

(Specific latent of fusion of ice $L = 3.36 \times 10^5 \text{ Jkg}^{-1}$, specific heat capacity of water, $c = 4200 \text{ Jkg}^{-1}\text{K}^{-1}$, specific heat capacity of copper = $400 \text{ Jkg}^{-1}\text{K}^{-1}$.)

(i) Derive an expression for the amount of heat gained by ice to melt it and raise its temperature to $X^{\circ}\text{C}$ (2mks)

(ii) Derive an expression for the amount of heat lost by the calorimeter and its content when their temperature falls to $X^{\circ}\text{C}$. (2mks)

(iii) Determine the value of X.

(3mks)

15.(a) The moon goes round the earth at constant speed. Explain why it is true to say that the moon is accelerating. (1 mark)

(b) A string of negligible mass has a bucket tied at the end. The string is 60cm long and the bucket has a mass of 45g. The bucket is swung horizontally making 6 revolutions per second. Calculate:

(i) The angular velocity. (1 mark)

(ii) The centripetal acceleration. (2 marks)

(iii) The tension on the string. (2 marks)

(iv) The linear velocity. (1 mark)

(c) Figure 6 shows a body of mass; $m = 200g$ attached to the centre of a rotating table with a string. The radius of the string was varied and different values of angular velocity recorded. The mass of the body remained constant throughout the experiment.

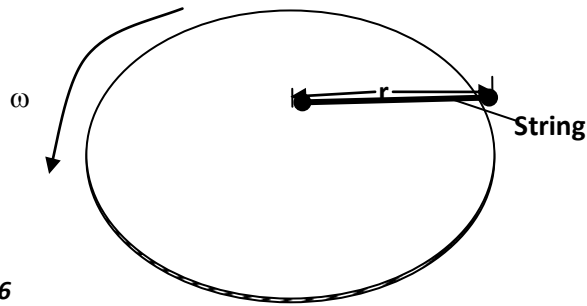
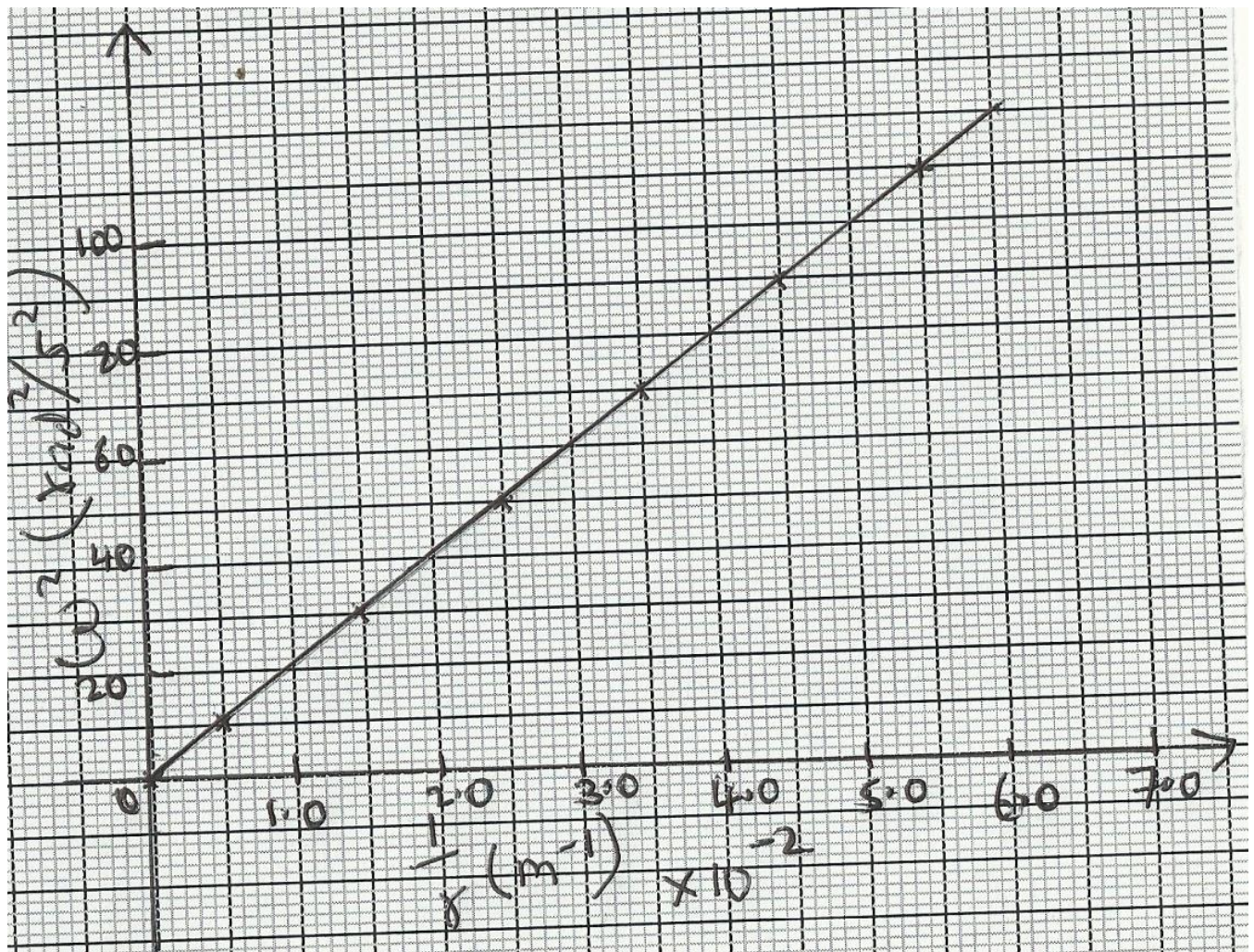

fig.6

The results obtained for angular velocity and radius were used to plot the following graph;



From the above graph;

(i) Calculate the value of the slope.

(2mks)

(ii) If ω^2 and $\frac{1}{r}$ are related by the equation; $\omega^2 = \frac{p}{r} \times \frac{1}{m}$, find the value of **P**. (2mks)

(iii) State the significance of **P**. (1mk)

THIS IS THE LAST PRINTED PAGE

SUCCESS