

# SUNSHINE SECONDARY SCHOOL MOCK 2015

## MATHEMATICS PAPER 2

### SECTION A

1. Evaluate using logarithm (4 marks)

$$\sqrt{\frac{4.283x(0.009478)^2}{\log 9.814}}$$

2. Calculate the density of the material used to make a concrete culvert of mass 1 million grams, internal diameter 0.72m, thickness 70mm and length  $2 \times 10^{-3} km$  (giving the answer in  $kgm^{-3}$  and in standard form)

(3 marks)

3. Simplify  $\frac{3}{\sqrt{5}-2} + \frac{1}{\sqrt{5}}$  leaving the answer in the form  $a + b\sqrt{c}$ , where a, b and c are rational numbers (3 marks)

4. The figure below shows a circle center O, radius 10 cm. The chord PQ = 16cm. Calculate the area of the unshaded region. (3 marks)

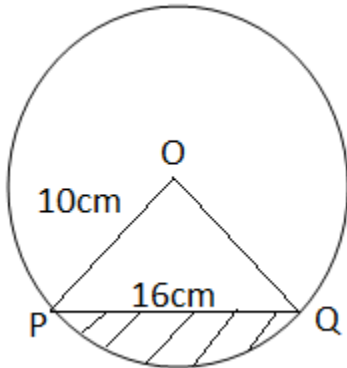

5. Solve the equation  $3x^2 + x - 4 = 0$  by the method of completing the square. (3 marks)

6. Two towns A and B are 200m apart. From the top of A, the angle of elevation of the top of B is  $15^\circ$ . From the top of B, the angle of depression of the bottom of A is  $40^\circ$ . Find the height of A. (3 marks)

7. The first, the third and the seventh term of an increasing arithmetic progression are three consecutive terms of a geometric progression. If the first term of the arithmetic progression is 10, find the common difference of the arithmetic progression (3 marks)

8. Peter operates a printing firm and the cost of printing a book is partly constant and partly varies as the number as pages. If a book has 200 pages, the cost is sh 400 and if it has 100 pages, the cost is sh 240. Find the cost of printing a book with 400 pages. (3 marks)

9. A and B are two matrices. If  $A = \begin{pmatrix} 1 & 2 \\ 4 & 3 \end{pmatrix}$  find B given that  $A^2 = A + B$  (3 marks)

10. Find the constant term in the expansion  $\left(3x - \frac{1}{2x}\right)^8$ . Hence state its value (3 marks)

11. Given that  $x = 31.01$ ,  $y = 12.9$  and  $w = 0.0023$ . Calculate the percentage error of  $\frac{y}{xw}$ , give your answer to 4 dp. (3 marks)

12. Evaluate  $\int_{-1}^3 (2x + 3) dx$  (3 marks)

13. A merchant blends 350kg of tea costing Sh. 84 kg with 140kg of tea costing Sh. 105 per kg. At what price must he sell the mixture to gain 25% (3 marks)

14. Solve for x given that;

$$3 \sin (3x - 20^\circ) = -2 \text{ for } 0^\circ \leq x \leq 180^\circ \quad (4 \text{ marks})$$

15.  $4x^2 - 10x + 4y^2 + 12y - 1 = 0$  represents a circle centre C (a, b) and of radius K. Find the values of a, b and K. (3 marks)

16. ABC is an equilateral triangle. P is a variable point on the same side of AB as C, and on the same plane such that angle APB =  $60^\circ$ . Use a ruler and a pair of compasses only to construct the locus of P. Describe the locus of P fully. (3 marks)

### **SECTION B**

17. Four buildings A, B, C and D stand on a level ground such that B is 240m on a bearing of  $60^{\circ}$  from A. C is south east of B and east of A. D is 320m from C on a bearing of  $150^{\circ}$  from A.

a) i) Use scales of 1 cm rep 40m draw accurately the points ABCD. (3 marks)

ii) Use the drawing to find the direction of B and D. (1 mark)

b) The height of building A is 200m and that of B is 80m. Determine the angle of depression of the top of building B from the top of building A. (3 marks)

c) Enter the layout of Kamau's plot shown below in a surveyor's book. (Unit in metres) (3 marks)



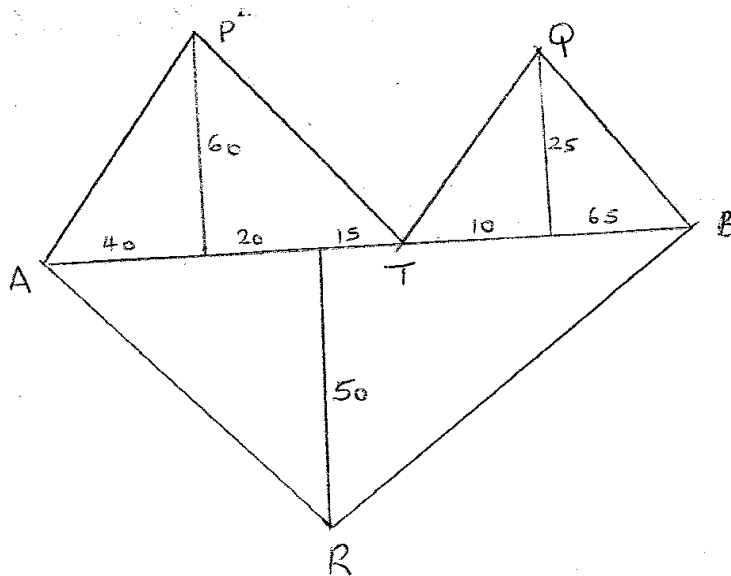

18. The table shows the marks obtained by 40 candidates in an examination

Marks	5-14	15-29	30-34	35-44	45-49
Frequency	2	12	7	15	x

(a) Find the value of x

(2 marks)

(b) On the grid provided below draw a histogram to represent the data (5 marks)

(c) By drawing a straight line on the graph above determine the median mark  
(3 marks)

19. The diagram below shows a bucket with top diameter 30cm and bottom diameter 20cm. The height of the bucket is 28cm.

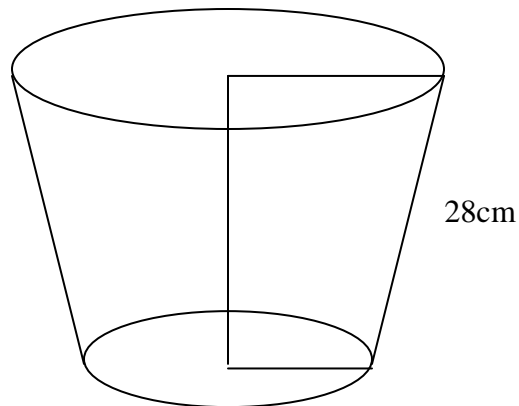

Find;

(a) The capacity of the bucket in litres.

(5 marks)

(b) The area of the metal sheet required to make 100 such buckets, taking 10% extra overlapping and wastage. (5 marks)

20. (a)

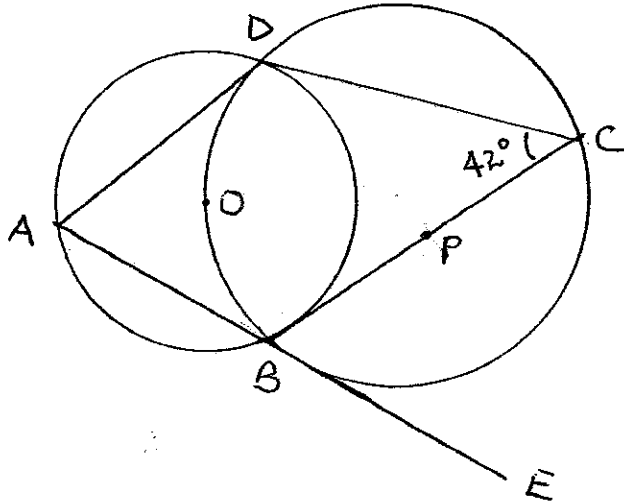

Giving reasons, determine the size of:

a) Angle CBD (2 marks)

b) Angle ODB (2 marks)

c) Angle BAD (2 marks)

d) Angle ABC (2 marks)

e) Angle ODA (2 marks)

21. A car leaves town X for town Y 120 km away at an average speed of 80 km/hr at 8.30 a.m. At the same time a bus leaves town Y for town X at an average speed of 60 km/hr. At 8.45 a.m., a cyclist leaves town Y for town X at an average speed of 30 km/hr.

(a) Calculate the time when the bus meets the car to the nearest minute. (3 marks)

(b) Calculate the distance between the car and the bus by the time the cyclist meets the car. (4 marks)

(c) If the bus upon reaching town X stops for 10 minutes then starts its journey back to Y, Calculate how far from X the bus meets the cyclist. (3 marks)

22. Two bags A and B contain identical balls except for the colours. Bag A contains 4 red balls and 2 yellow balls. Bag B contains 2 red balls and 3 yellow balls.

a) If a ball is drawn at random from each bag, find the probability that both balls are of the same colour. (4 marks)

b) If two balls are drawn at random from each bag, one at a time without replacement, find the probability that:

i) The two balls drawn from bag A or bag B are red (4 marks)

ii) All the four balls drawn are red (2 marks)

23. The figure below shows a cross-section of a tunnel.

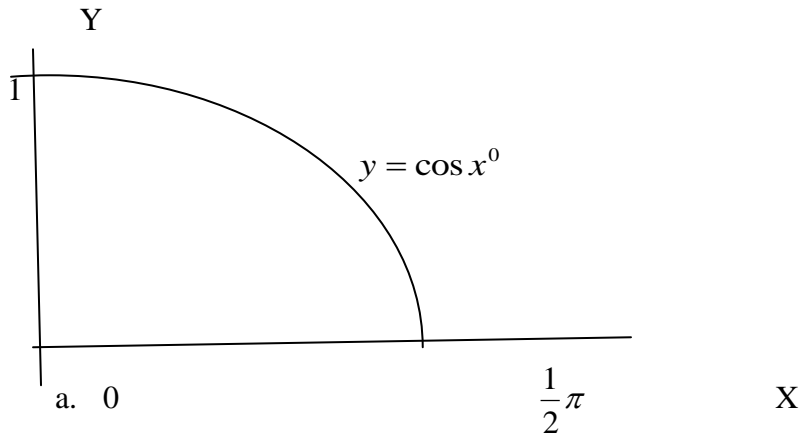

Determine the difference in area of the cross section if trapeziums rule rather than mid ordinate rule was used using six strips to estimate the area. (10 marks)

24. (a) Draw the graph of the function below on the grid provided

$$y = 2x^2 - 7x - 2 \text{ for the values of } -1 \leq x \leq 6$$

(5 marks)

(b) From your graph determine the roots of the function.  $2x^2 - 7x - 2 = 0$ . (1 marks)

(c) By drawing a suitable graph of function  $y = 2x - 7$  on the same axis, solve the simultaneous equations  $y = 2x^2 - 7x - 2$  and  $y = 2x - 7$ . (4 marks)



